

SÛLION



BUILT

CAMPANA LED



BUILT CAMPANA LED

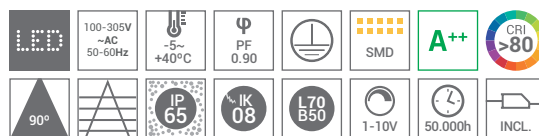

Regulable
Dimmable
Réglable
Ajustável

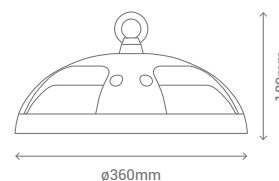

REF	W	LM	CCT
101182	150W	20050Lm	4000K
100757	100W	12000Lm	4000K

COLOR Negro
MATERIAL Metal y aluminio
DIFUSOR Acrílico

COLOUR Black
MATERIAL Metal and aluminium
DIFUSER Acrylic

COULEUR Noir
MATÉRIEL Métal et aluminium
DIFFUSEUR Acrylique

COR Preto
MATERIAL Metal e alumínio
DIFUSOR Acrílico



BUILT ESPECIFICACIONES

Luminaria industrial de alta potencia y lúmenes, 100W con 12000 lúmenes y 150W con 20050. Está destinada a zonas de trabajo, almacenes, etc.

High power and increased performance industrial luminaire, 100W with 12000lms and 150W with 20050lms. Suitable for operating areas, warehouses, etc.



Fabricada con un sistema de intercambio fácil de lente, tenemos disponible una lente en 50° (50624), para zonas especiales de iluminación.

Built with an easy lens exchange system, we have a 50° lens available (50624) for special lighting areas.

Instalación incluida suspendida o para casos especiales disponemos de una fijación directa a techo (50626). Se puede también incorporar un sensor (50625), para adecuarse a una necesidad especial con este requerimiento.

Accessories for suspended installation included. For special uses, a ceiling fixing accessory (50626) is available. A motion sensor (50625) can also be incorporated to meet special needs.



BUILT ESTUDIO DE AMORTIZACIÓN

CONDICIONES DE USO / TERMS OF USE / CONDITIONS D'UTILISATION

Horas diarias de funcionamiento / Daily operation hours / Heures de fonctionnement par jour	24h
Días de funcionamiento anual / Annual operating days / Jours de fonctionnement par an	365

PARÁMETROS DE CÁLCULO / PARAMETERS OF COMPUTATION / PARAMÈTRES D'ESTIMATION

Precio energía / Energy price / Prix de l'énergie	0,16kWh
Coste mano de obra / Labour cost / Coût de la main-d'œuvre	30€/h
Tiempo de instalación por equipo / Installation time per item / Temps d'installation par équipement	1h

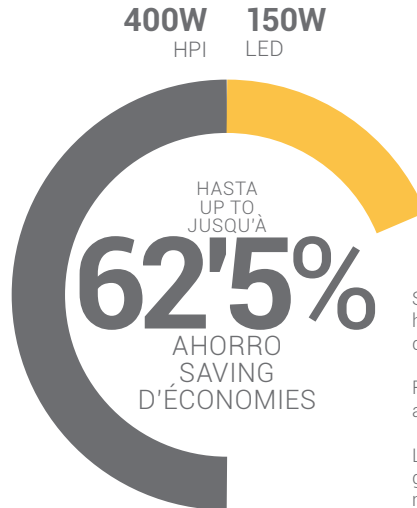

Sustitución de campanas industriales con lámpara de halogenuro metálico en 250W y 400W, por campanas de LED en 100W y 150W.

Replacement 250W and 400W HPI luminaries by 100W and 250W LED luminaries.

Les gamelles LED de 100W et 250W remplacent les gamelles industrielles avec luminaire d'halogénure métallique de 250W et 400W.

INSTALACIÓN ACTUAL / CURRENT INSTALLATION / INSTALLATION ACTUELLE		NUEVA INSTALACIÓN / NEW INSTALLATION / INSTALLATION NOUVELLE	
CAMPANA / HIGHBAY / GABELLE 250W		CAMPANA LED / HIGHBAY LED / GABELLE LED	
Unidades / Units / Unités	10	10	Unidades / Units / Unités
Vida útil / Lifetime / Vie utile	5.000h	30.000h	Vida útil / Lifetime / Vie utile
Precio unidad / Unit price / Prix unité	142,00€	277,00€	Precio unidad / Unit price / Prix unité
Coste anual de energía / Annual energy cost / Coût annuel d'énergie	9.110,40€	3.504,00€	Coste anual de energía / Annual energy cost / Coût annuel d'énergie
Coste anual de reposición de material / Annual cost of replacement / Coût annuel de remplacement	0,11€	2.770,00€	Coste material / Material cost / Coût de matériel
		600,00€	Coste mano de obra / Labour cost / Coût de main d'œuvre
		3.370,00€	Coste total de nueva instalación / Total cost new installation / Coût total de la nouvelle installation
		0,01€	Coste anual de reposición de material / Annual cost of replacement / Coût annuel de remplacement

RETORNO DE INVERSIÓN / RETURN ON INVESTMENT / RETOURS SUR INVESTISSEMENT

Coste anual nueva instalación / Annual cost of new installation / Coût annuel de nouvelle installation	3.504,00€
Coste anual antigua instalación / Annual cost of old installation / Coût annuel de l'installation actuelle	9.110,40€
Ahorro total anual / Total annual savings / Économies annuelles	5.606,40€
Inversión / Investment / Investissement	3.370,00€
Período amortización (años) / Amortization period (years) / Période d'amortissement (ans)	0,60



BUILT ACCESORIOS

SUSTITUYE CAMPANAS DE HALOGENURO METÁLICO DE 400W
REPLACES 400W METAL HALIDE HIGH BAY

REMPLECE CLOCHE DE HALOGÉNURE MÉTALLIQUES 400W
SUPRE CAMPANA DE HALOGENETO METÁLICO DE 400W



ÓPTICA

Óptica ángulo de apertura 50°
50° angle optic
Óptica ângulo de abertura 50°
Optique angle d'ouverture 50°

REF / 50624



SENSOR

Sensor
Sensor
Capteur
Sensor

REF / 50625



BRACKET

Bracket
Bracket
Bracket
Bracket

REF / 50626



BUILT PLANO TÉCNICO

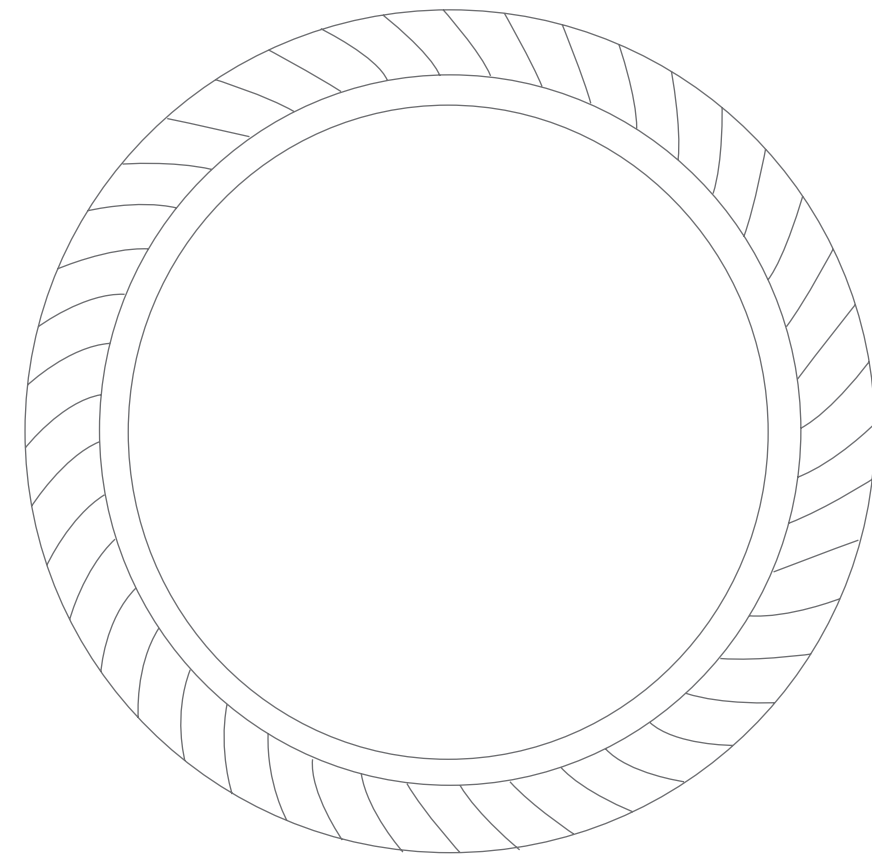
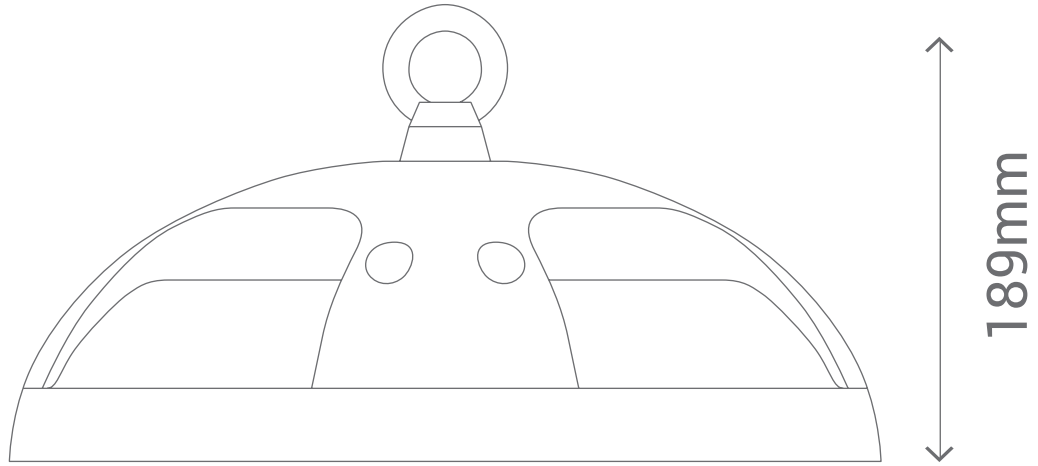

Ø360mm



**BUILT
CURVAS**

REF/100757

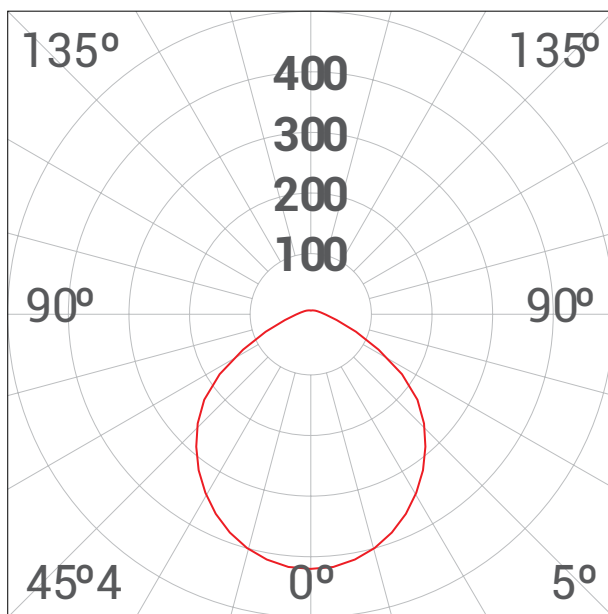

cd/klm — 90°-270° — 0°-180°

REF/101182

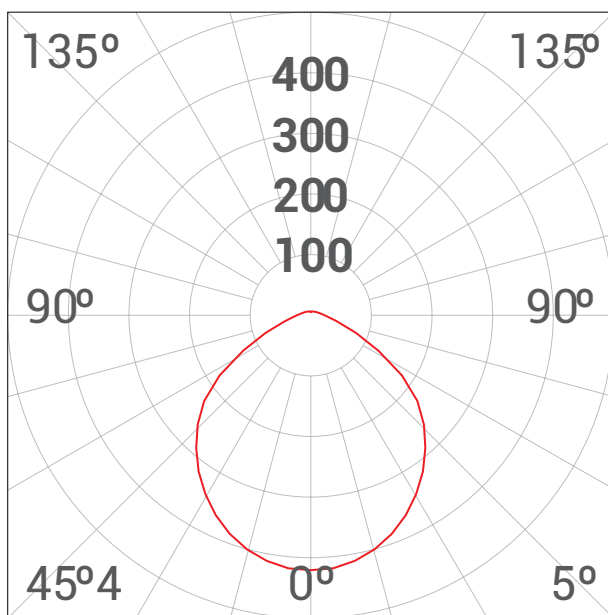

cd/klm — 90°-270° — 0°-180°



BUILT AMBIENTES



BUILT PACKAGING

BUILT

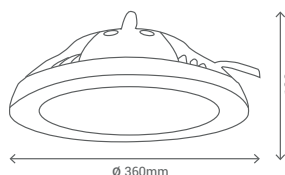

Campana 100W
High bay 100W

- 
- 
- 
- 
- 
- 
- 
- 
- 
- 

SÛLION

100757

 Esta luminaria lleva lámparas LED incorporadas.

A++

A+

A

C

D

E

}

LED

Las lámparas de esta luminaria no son recambiables.

874/2012 



www.sulion.es

Calle Verano, 51
Polígono Industrial Las Monjas
28850 Torrejón de Ardoz / Madrid / ESPAÑA
CIF A28763647